

Transition Within SIP Based Multi-Party Communication: From Tightly-Coupled To Fully-Coupled Conference

Wajdi Elleuch, B. Ing., M.Sc.A.

Ph.D. Candidate

Université de Sherbrooke

Québec - Canada

Alain Houle, ing. Ph.D.

Professor

Université de Sherbrooke

Québec - Canada

CCECE-IEEE 2008

Niaga Falls – Canada



UNIVERSITÉ DE
SHERBROOKE



Outline

- ▶ Overview of conference models
- ▶ Motivations (Tightly-coupled model limitations)
- ▶ Solution (Fully-coupled transition)
 - ▶ Transitions overview
 - ▶ Transition steps
 - ▶ Transition Message protocol
- ▶ Evaluation of Transition Message Costs
- ▶ Conclusion

Overview of multiparty communication topology approaches

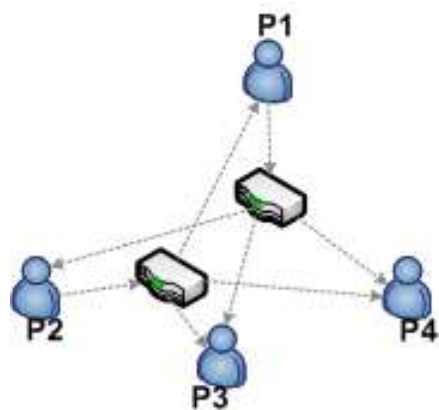

Loosely-coupled
(Multicast routing)

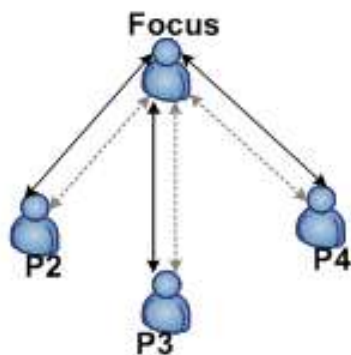

Tightly-coupled
signaling and media

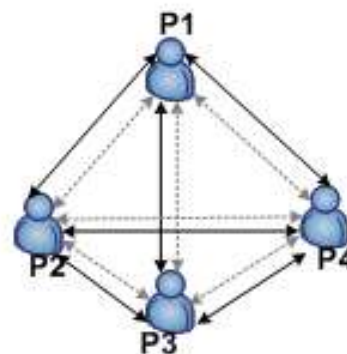

Fully-coupled signaling and
media

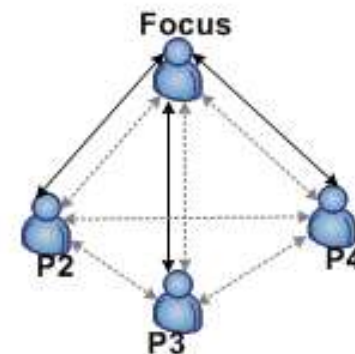

Tightly coupled signaling,
Fully-coupled media

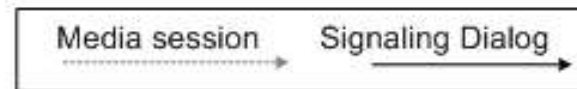

Multiparty communication topology approaches

Loosely-coupled approach

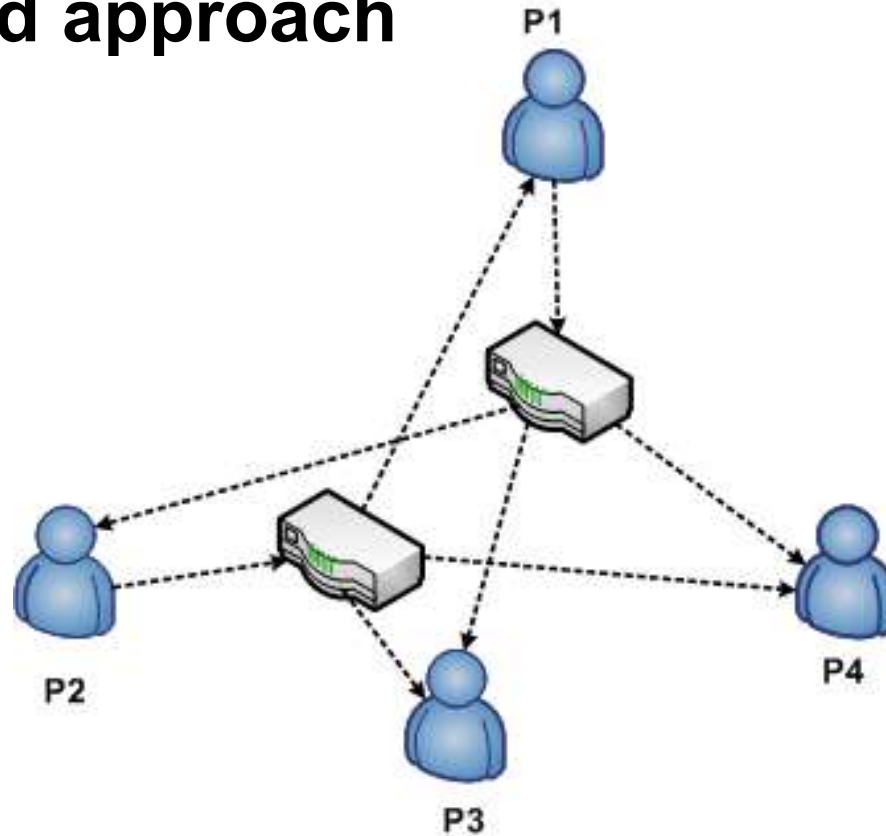

Multicast routing

Multiparty communication topology approaches

Tightly-coupled approach

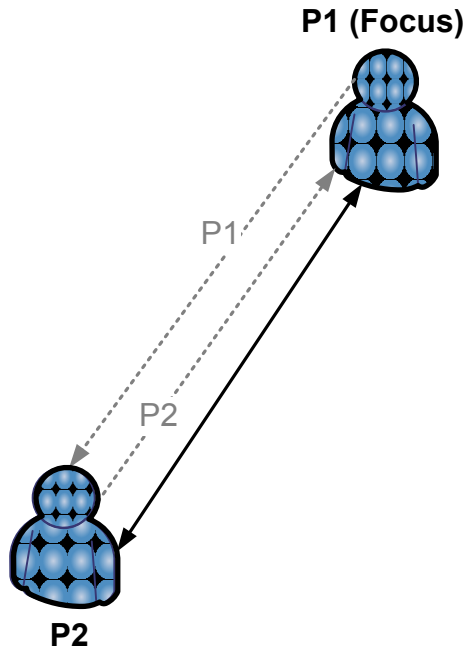

Multiparty communication topology approaches

Tightly-coupled approach

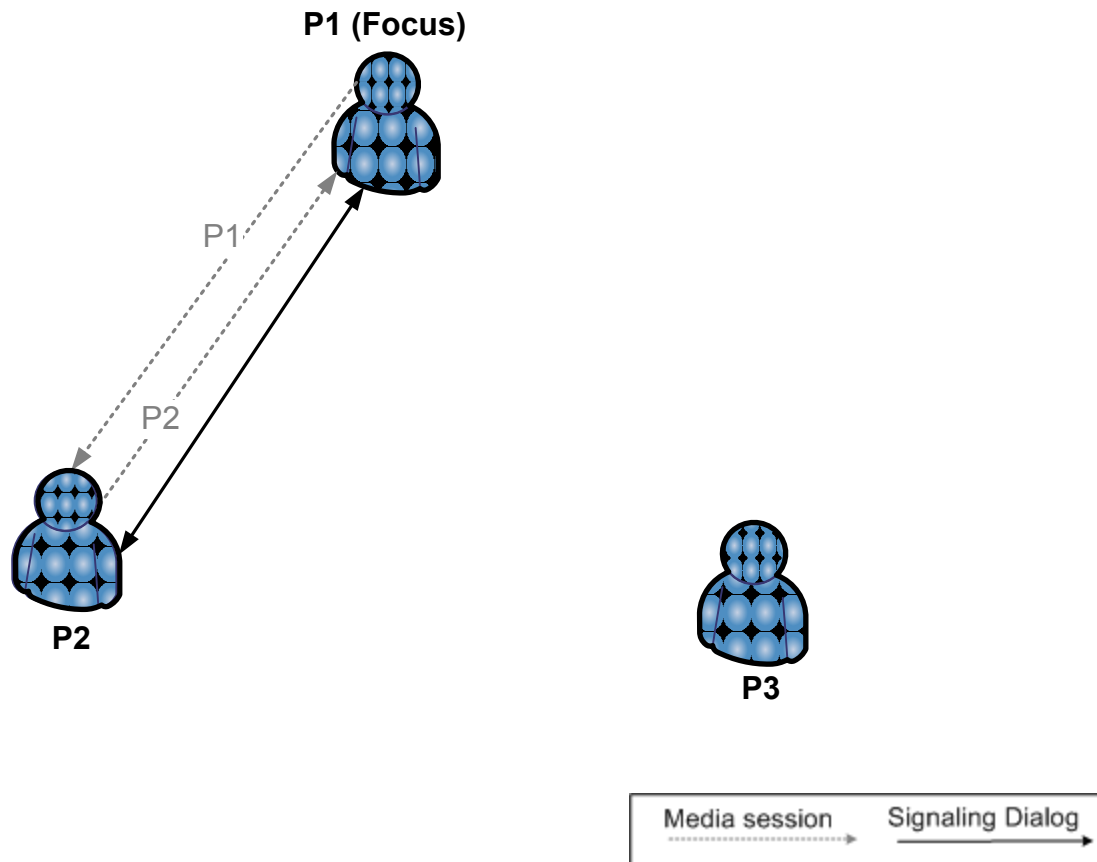

Multiparty communication topology approaches

Tightly-coupled approach

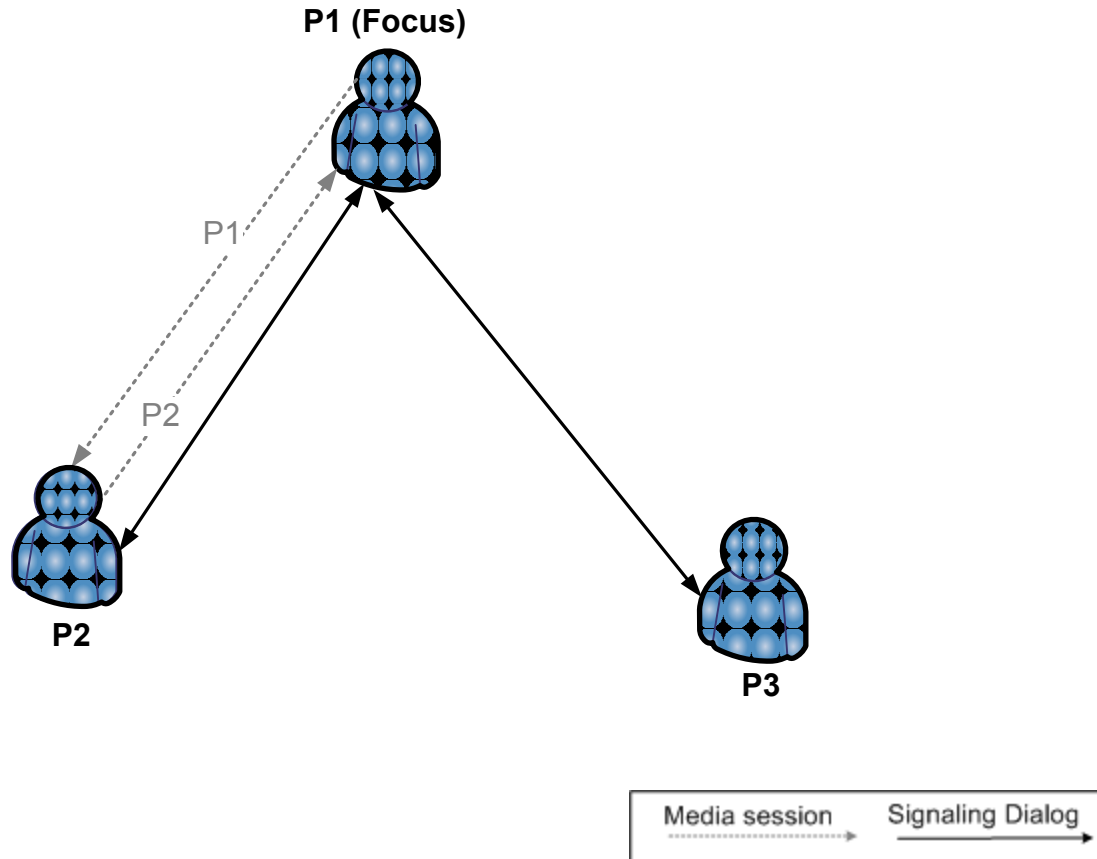

Multiparty communication topology approaches

Tightly-coupled approach

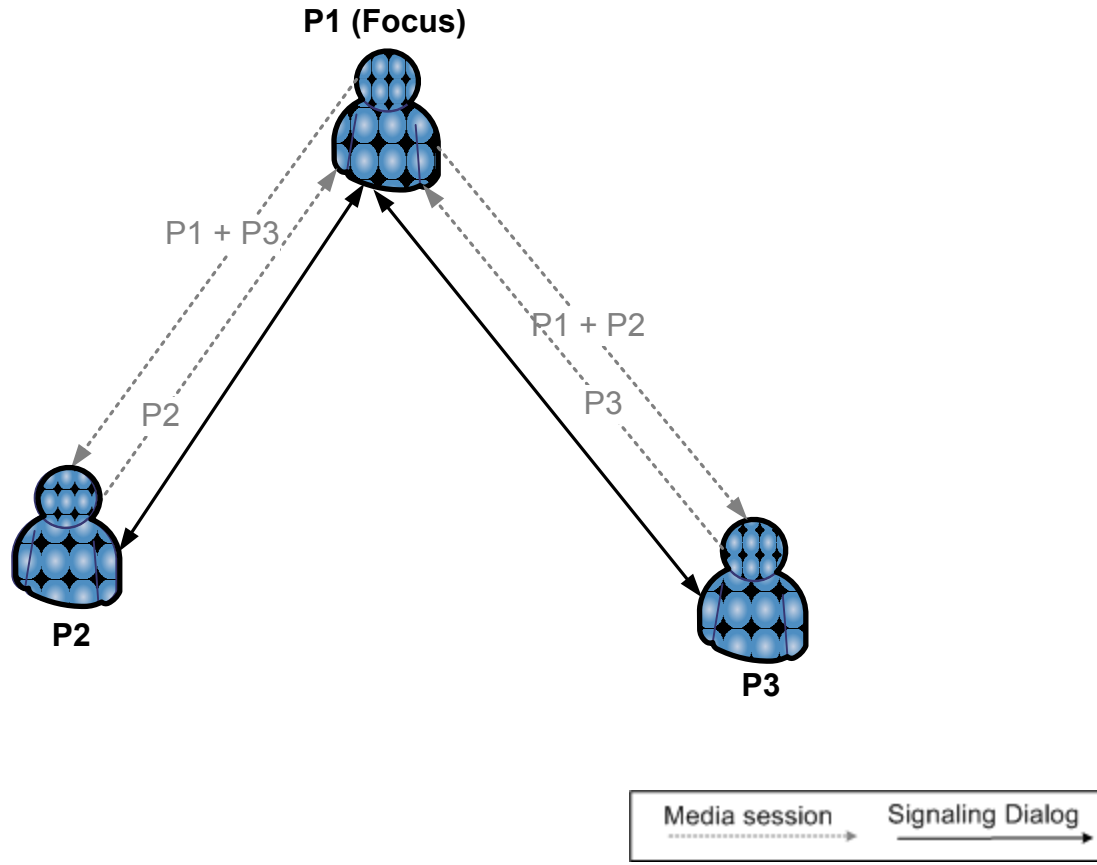

Multiparty communication topology approaches

Tightly-coupled approach

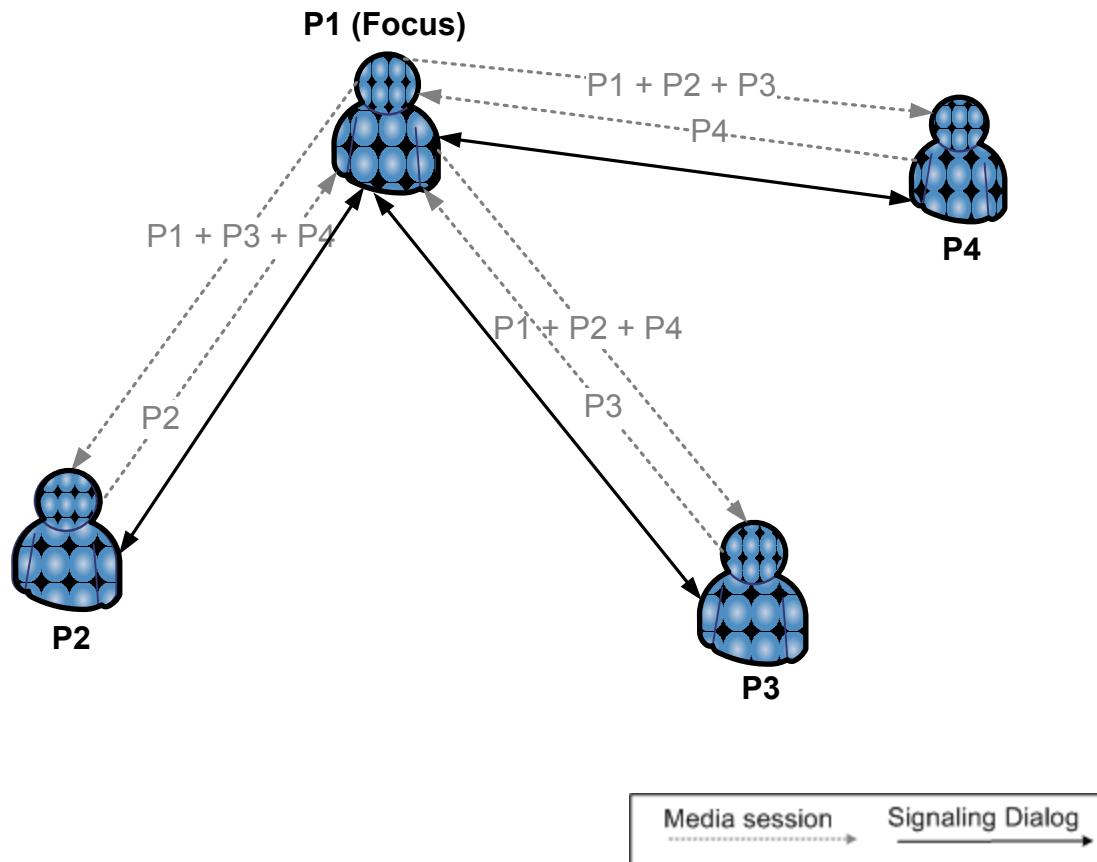

Multiparty communication topology approaches

Tightly-coupled approach

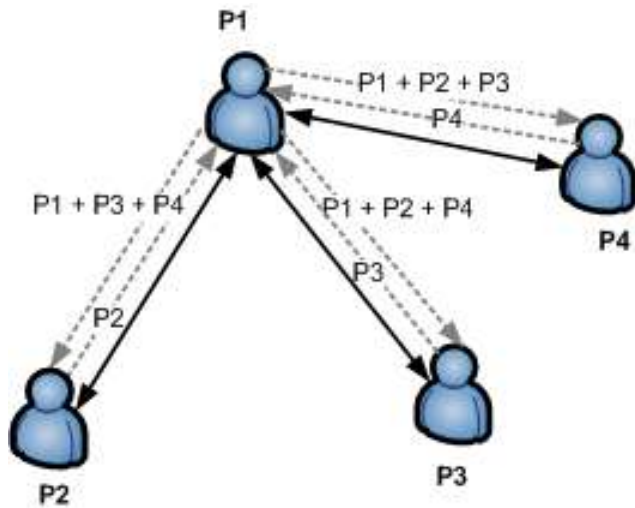

End-System Mixing

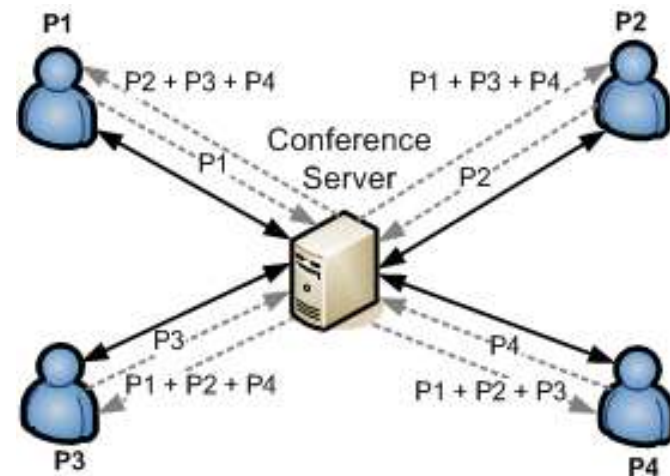

Server Mixing

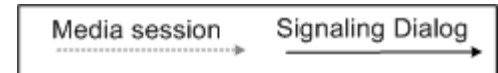

Multiparty communication topology approaches

Fully-coupled approach

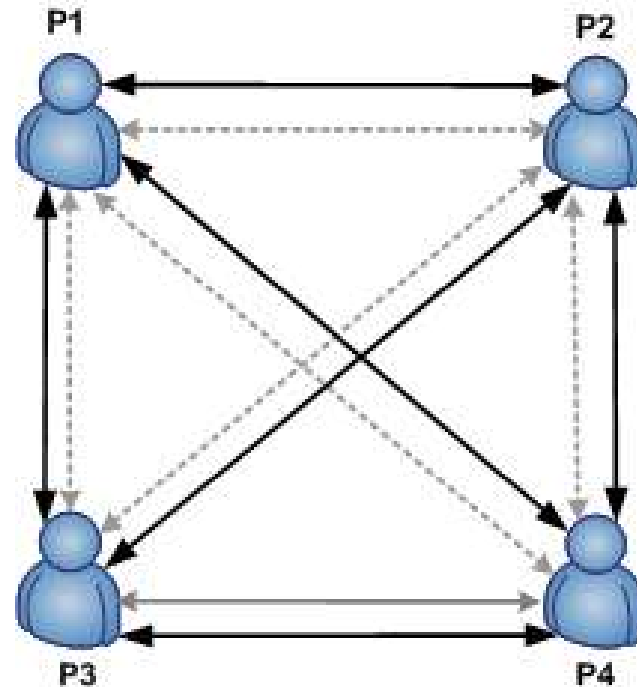

Fully-coupled



Multiparty communication topology approaches

Fully-coupled model establishment

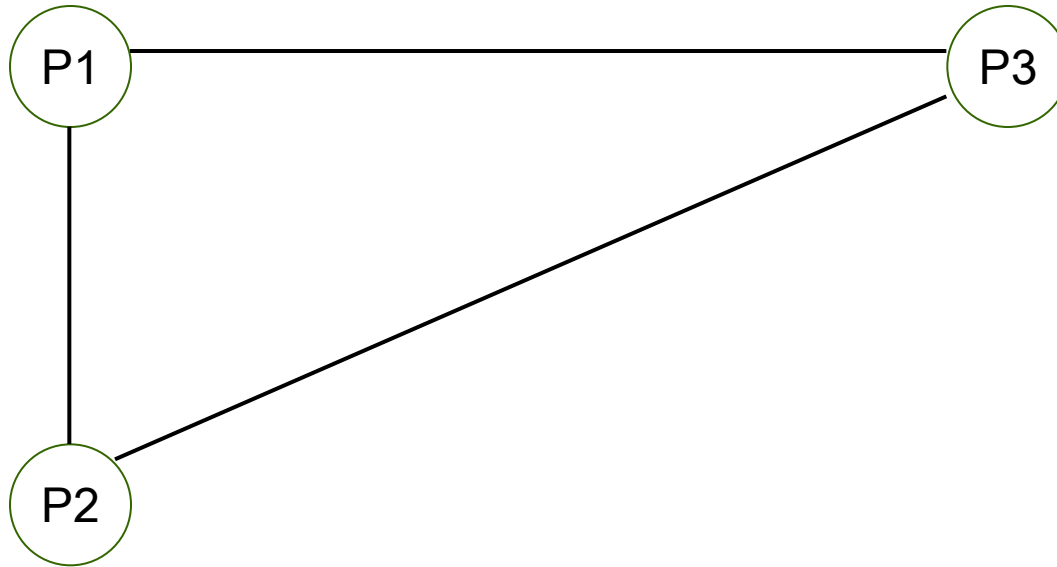

Multiparty communication topology approaches

Fully-coupled model establishment

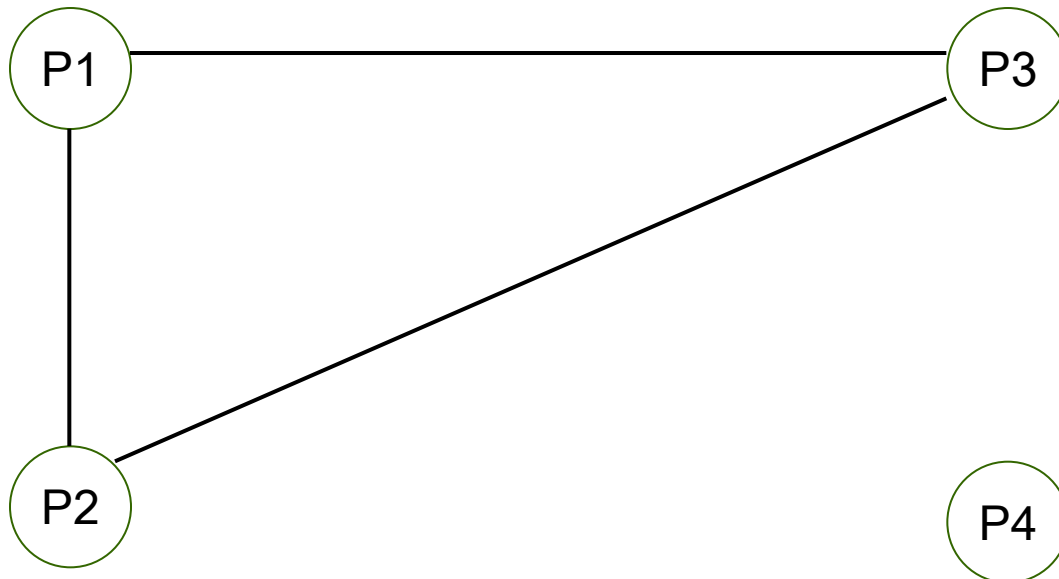

Multiparty communication topology approaches

Fully-coupled model establishment

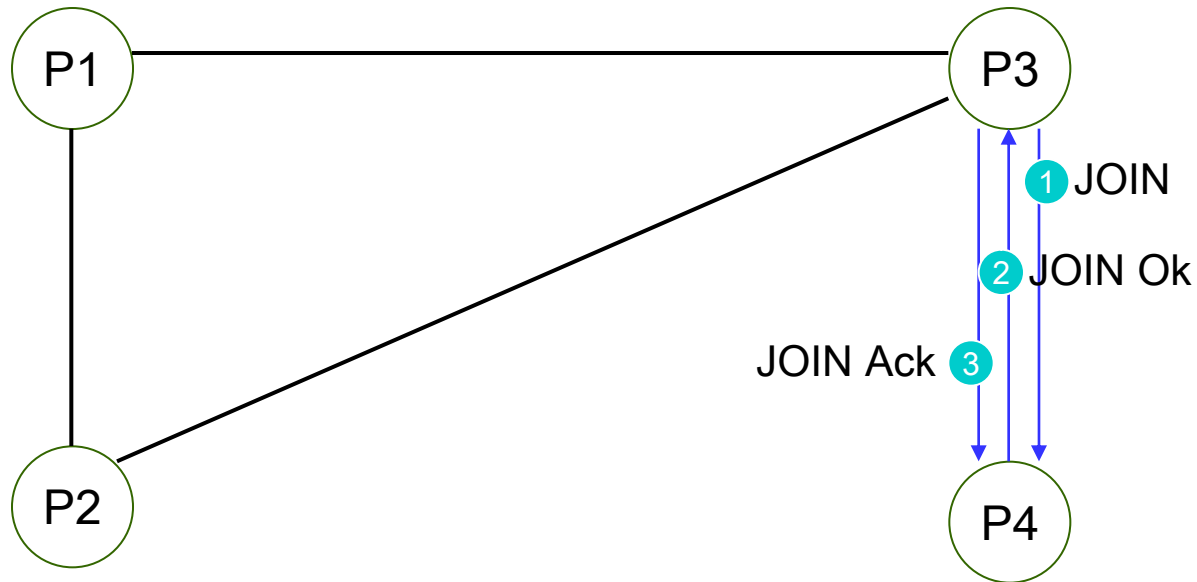

Multiparty communication topology approaches

Fully-coupled model establishment

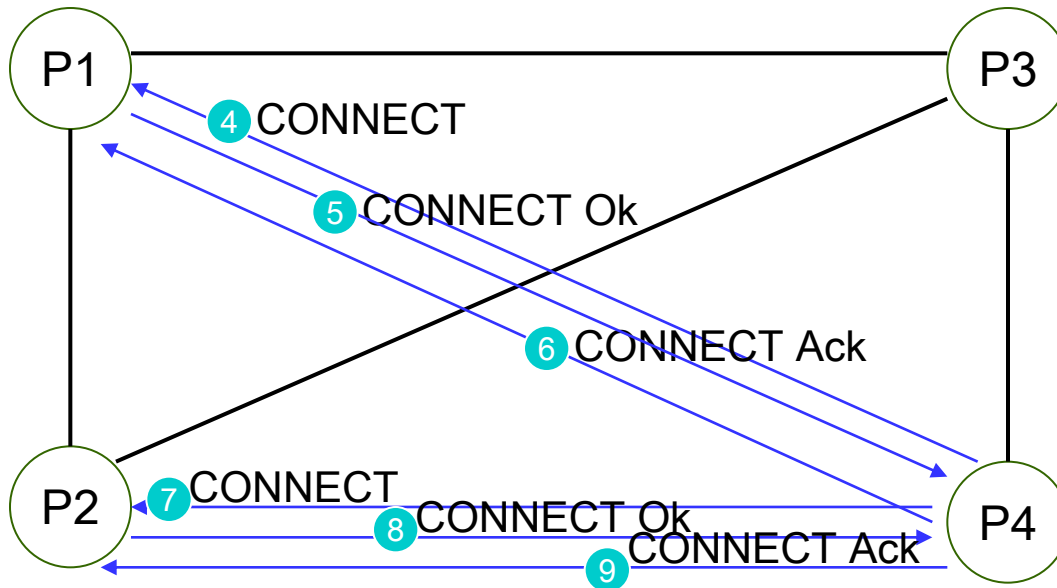

Multiparty communication topology approaches

Fully-coupled model establishment

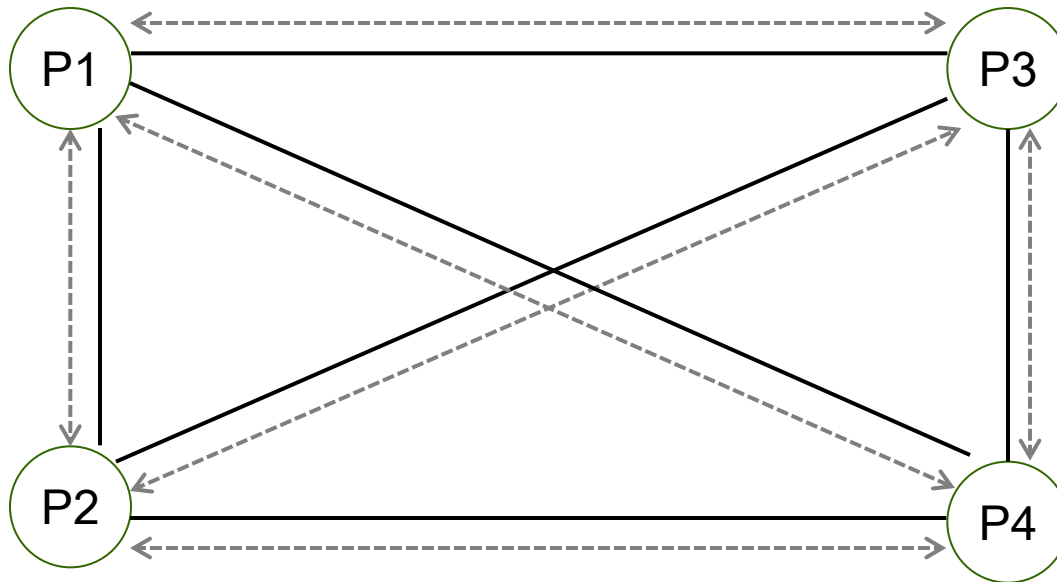

Multiparty communication topology approaches

Tightly-coupled Signaling, Fully-coupled Media approach

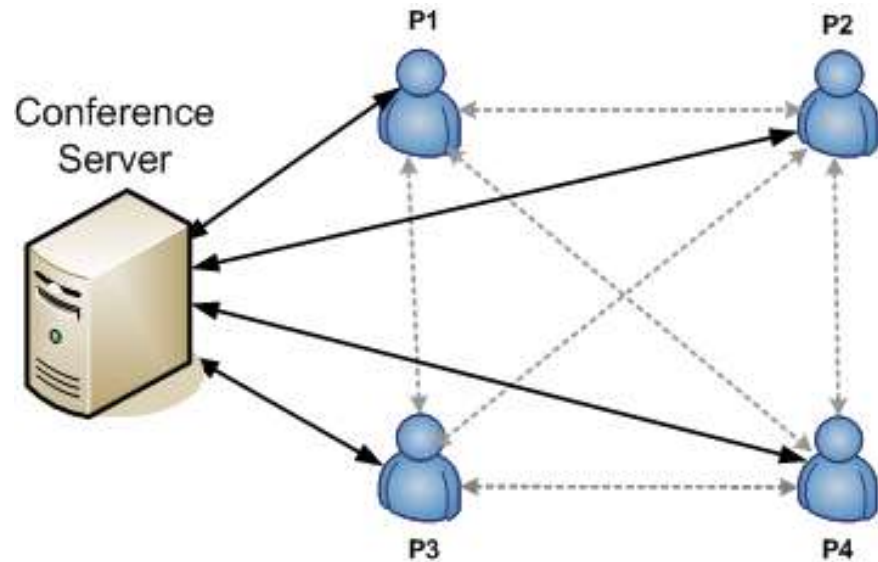

Tightly-coupled signaling,
Fully-coupled Media



Motivations

Tightly-coupled approach limitations

- ▶ Central point of failure (Focus)
- ▶ Conference-scale limited by Focus Bandwidth
- ▶ Possible Media process overload for Focus

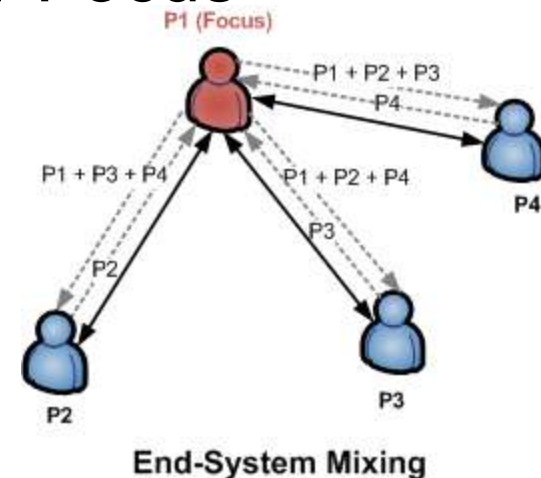

Solution

Transition from Tightly-coupled to Fully-coupled model

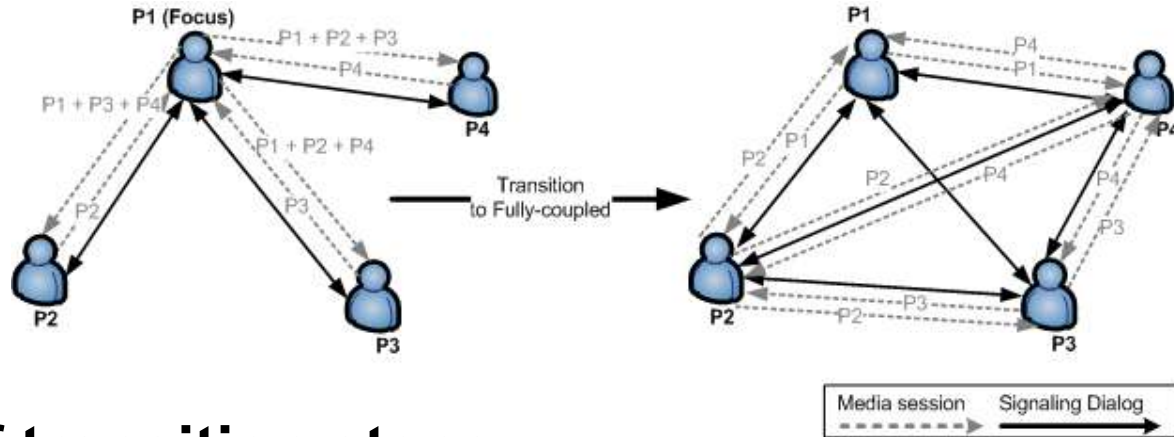

Overview of transition steps

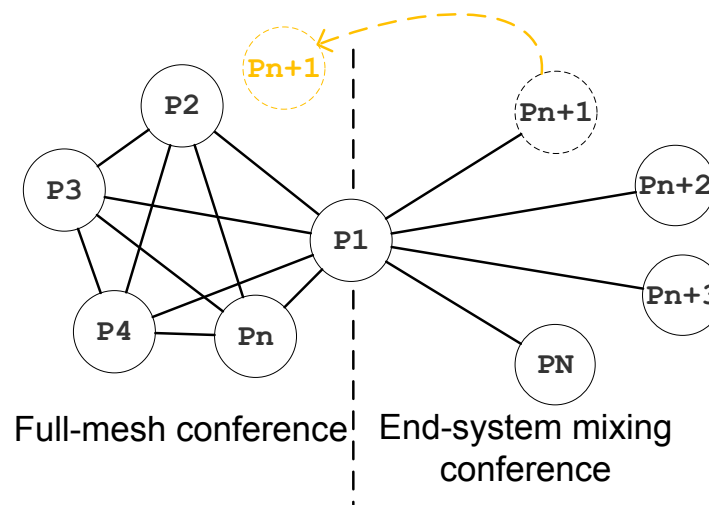

Solution

Transition Message protocol

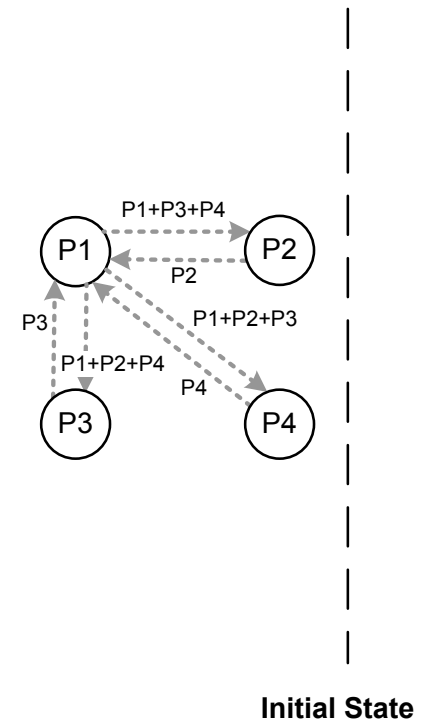

Solution

Transition Message protocol

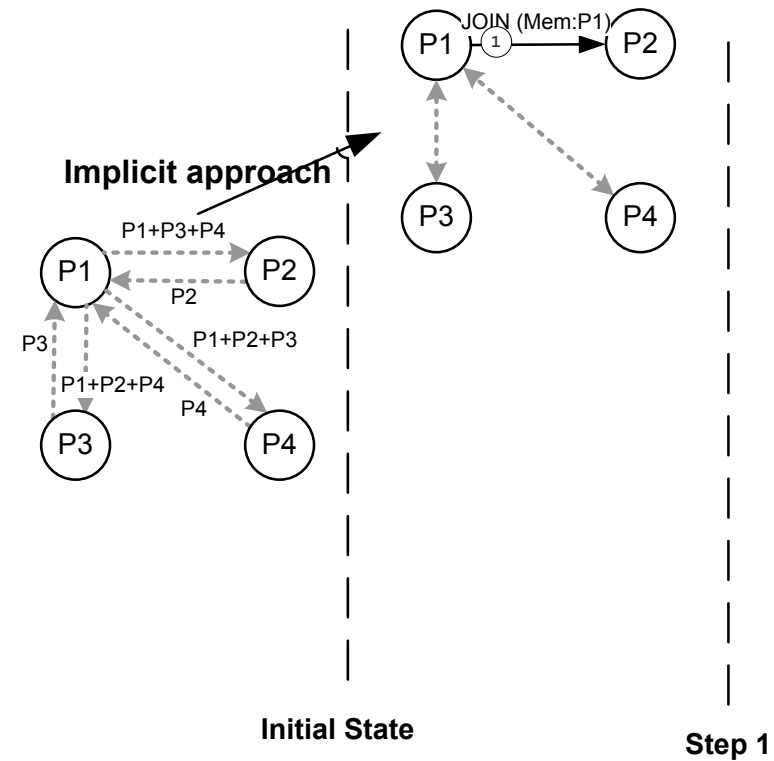

Solution

Transition Message protocol

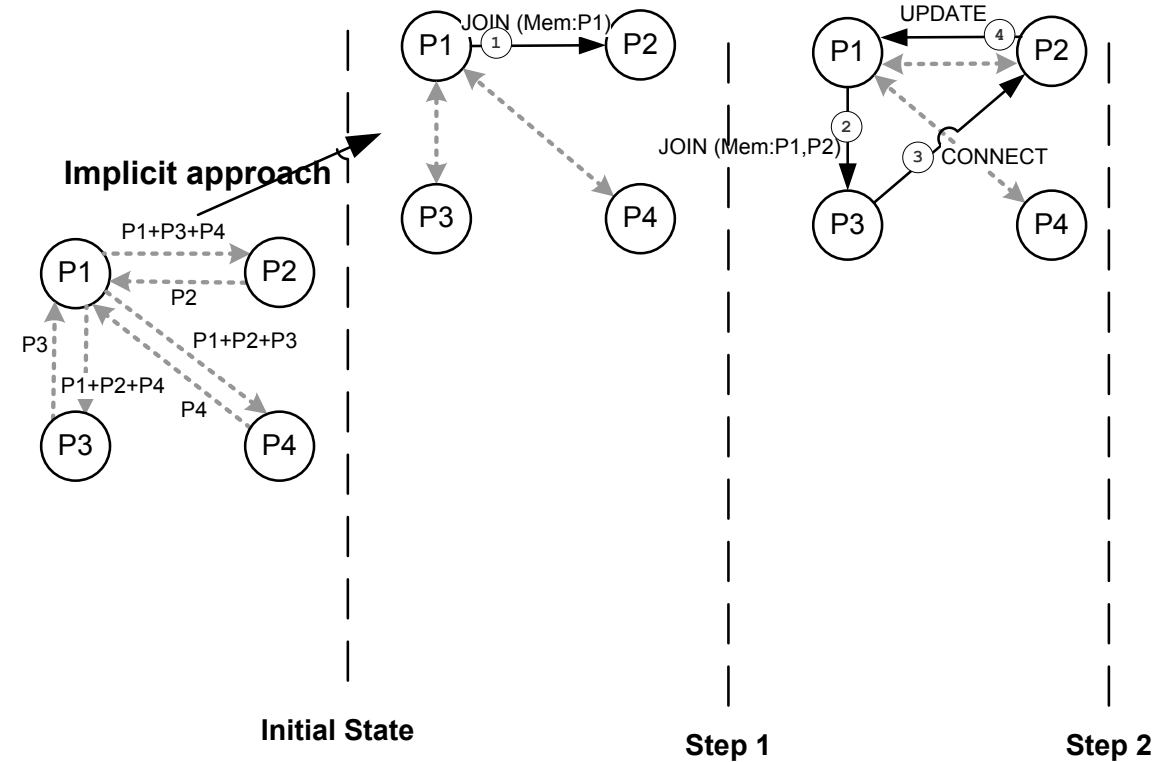

Solution

Transition Message protocol

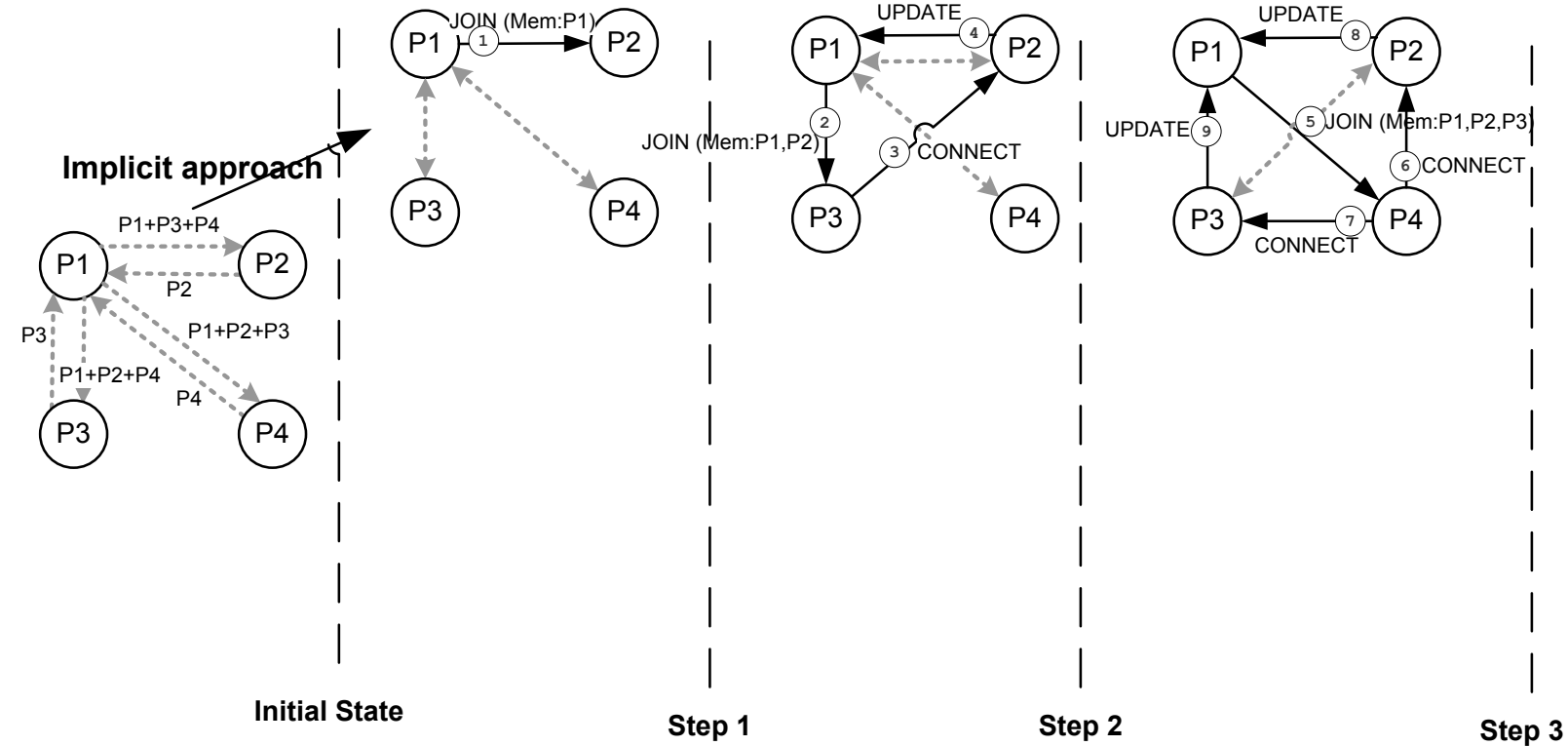

Solution

Transition Message protocol

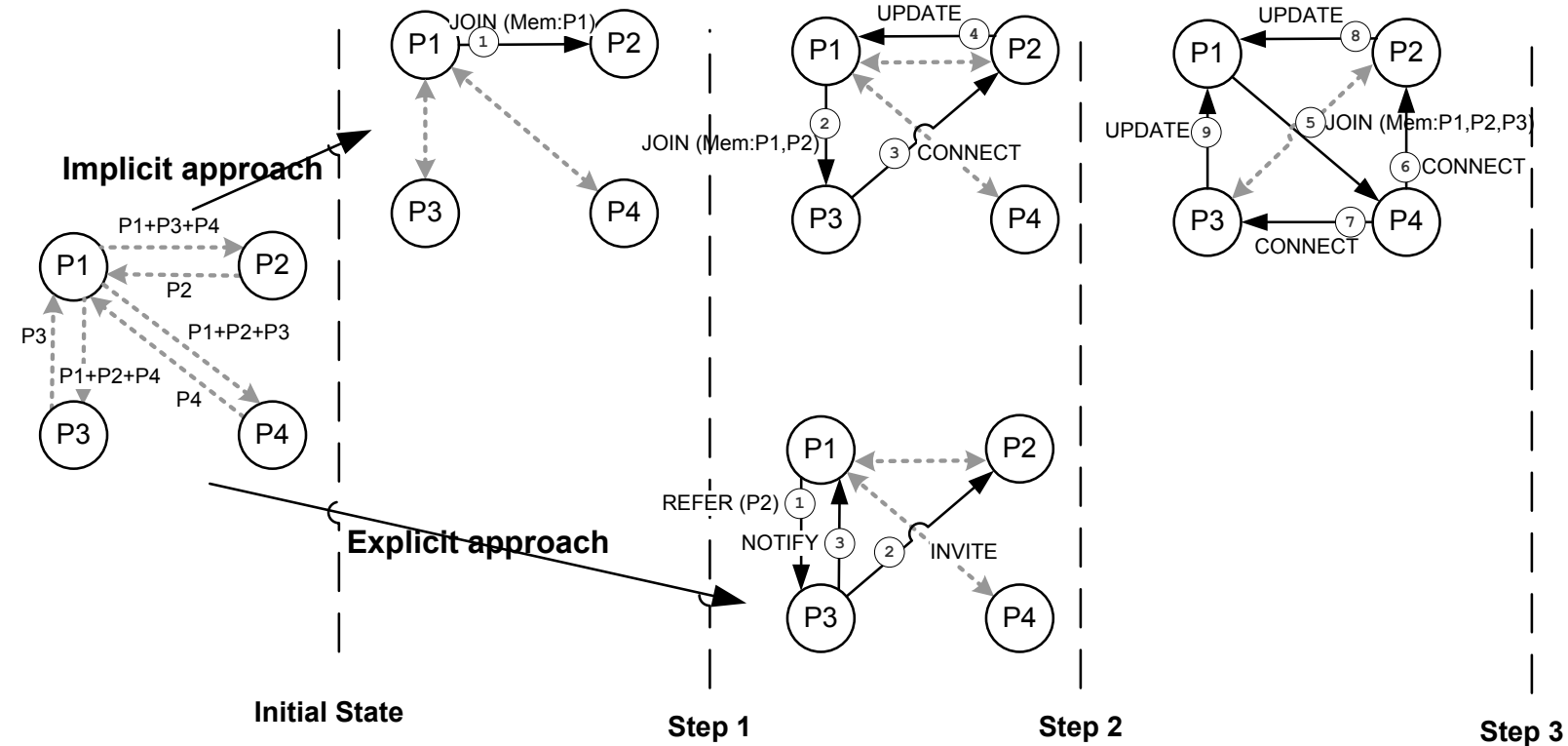

Solution

Transition Message protocol

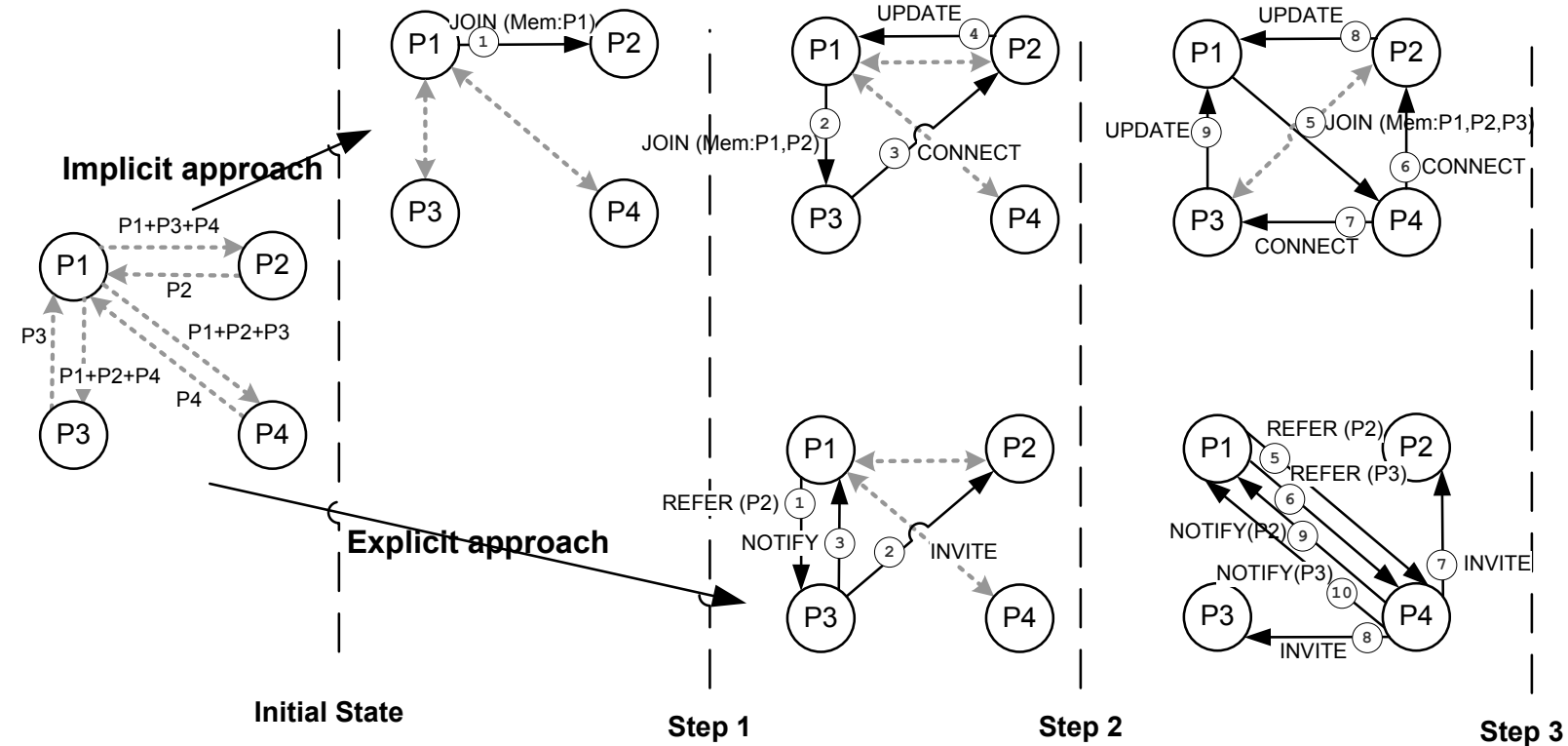

Solution

Transition Message protocol

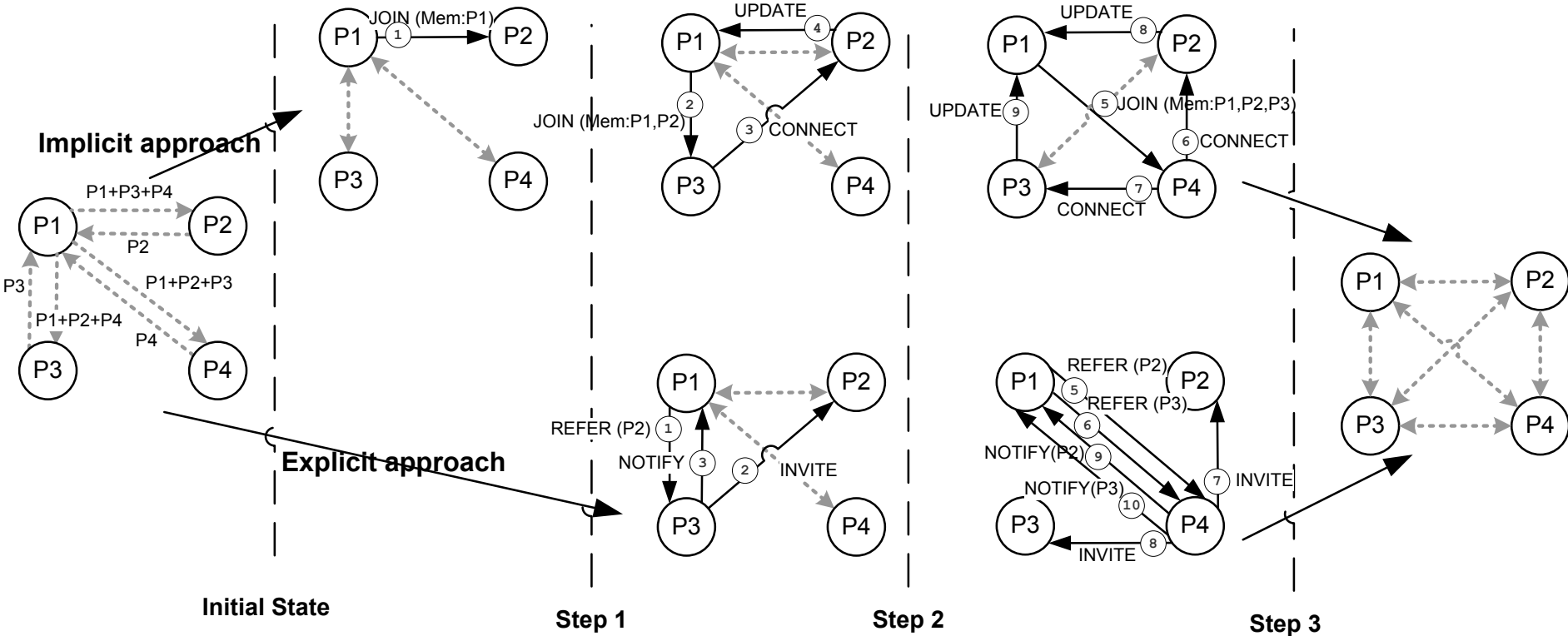

Transition Message Costs

Transition Cost: $T_{\text{cost}} = \sum_{i=1}^{N-1} (\text{Step}_{\text{cost}})i$

For explicit approach:

$$(\text{Step}_{\text{cost}})i = (\text{Refer}T_{\text{cost}} + \text{Invite}T_{\text{cost}} + \text{Notify}T_{\text{cost}}) * (i - 1)$$

For implicit approach:

$$(\text{Step}_{\text{cost}})i = \text{Join}T_{\text{cost}} + (\text{Connect}T_{\text{cost}} + \text{Update}T_{\text{cost}}) * (i - 1)$$

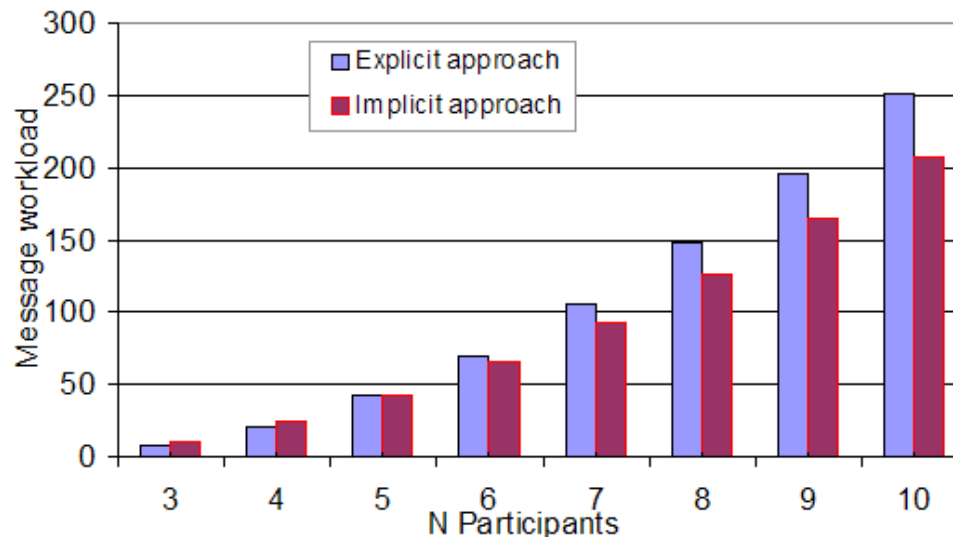

Conclusion

- ▶ We proposed SIP based solution to resolve tightly-coupled conference model limitations
- ▶ Two approaches are explored, and their performances compared (implicit and explicit)
- ▶ Some other solutions can also be considered:
 - ▶ Delegating media mixing load to another participant
 - ▶ Spreading media processing load upon available participants.

Conclusion

Thank you for your attention !! 😊

Questions ?