

The STORM Project

Analysis, Design and Implementation

- Wajdi Elleuch (Researcher Engineer)
- Samuel Guénette (Chief of Technology - M5T)
- Alain C. Houle (Professor - Université de Sherbrooke)
- Éric Rodrigue (Programmer - Mediatrix)

STORM : Overview

Black Phone and IP Phone interfaces are limited for advanced services

STORM is an interface allowing cooperation between a PC and an APA for advanced/new telephony services:

Example of new services :

- Make Call
- Caller Id
- Call History
- Voice Mail
- Call Recording
- Simple APA Configuration

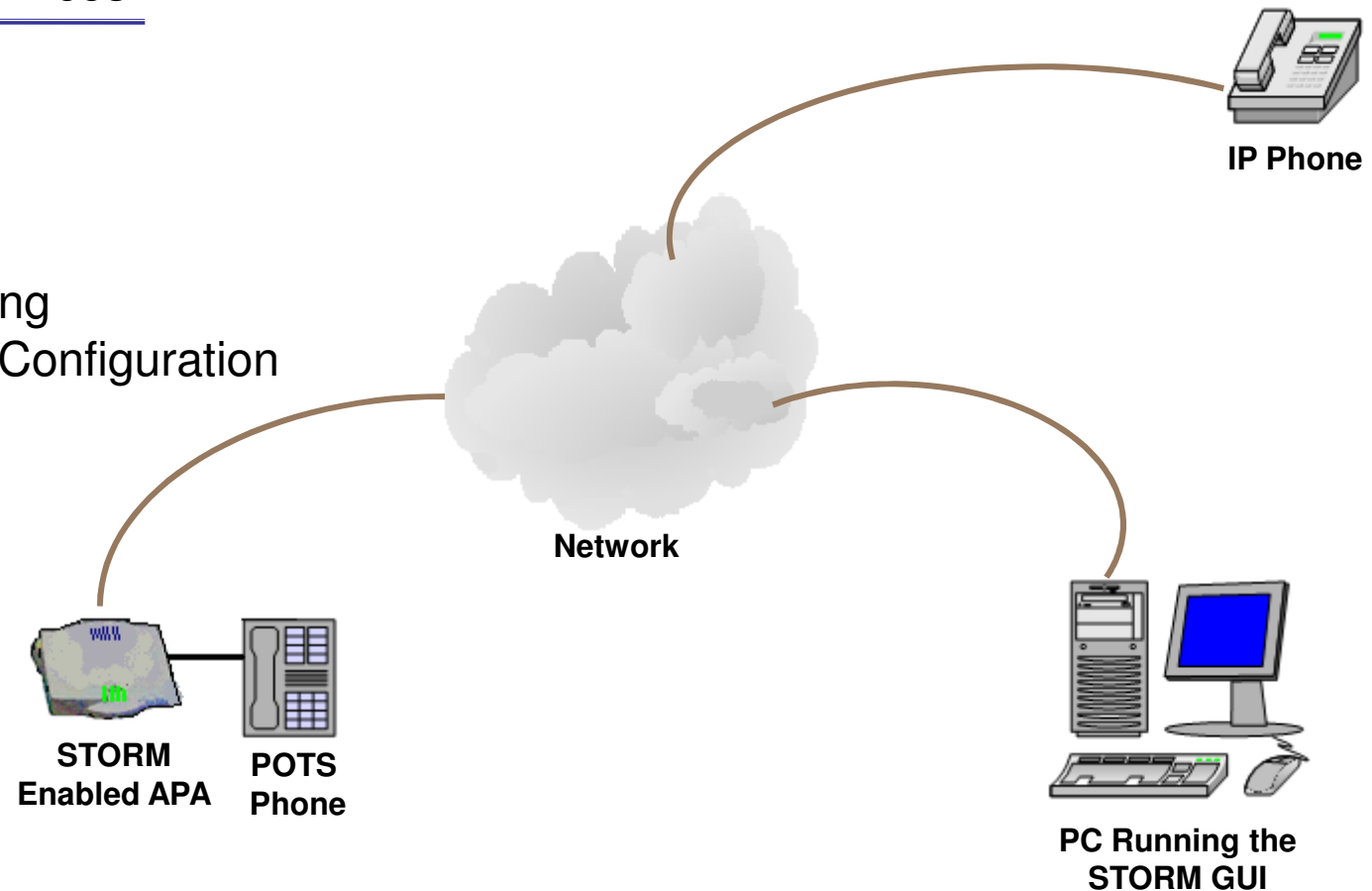

STORM : Service Use cases

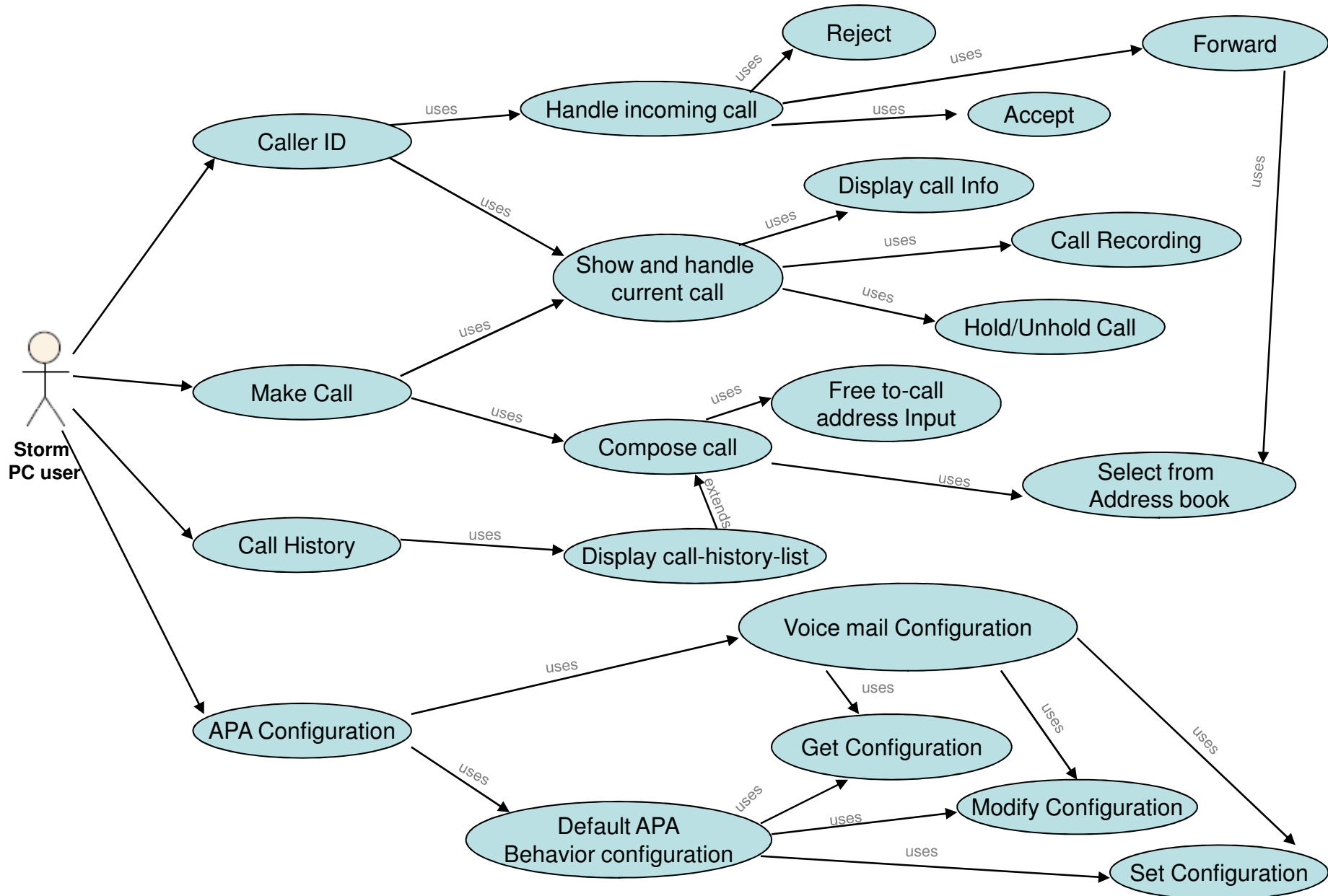

STORM : The Protocol ?

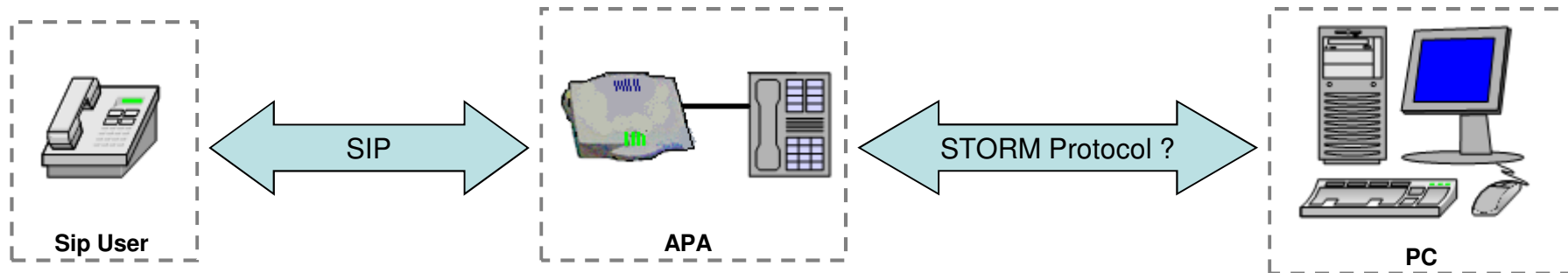

Distributed Object Technology ?

- JAVA/RMI : C++ Compatibility ?
- COM/DCOM : Compatibility with non-Microsoft systems ?
- CORBA : Text data support ? XML support ?

Web Services related technology to support XML ?

- XML/RPC: Limited XML structure (methodName, params, param, value)
- SOAP: Client/Server Model (slave/master)
- XML STORM: Use XML structure to describe the exchanged data between Storm devices

STORM : The Protocol ?

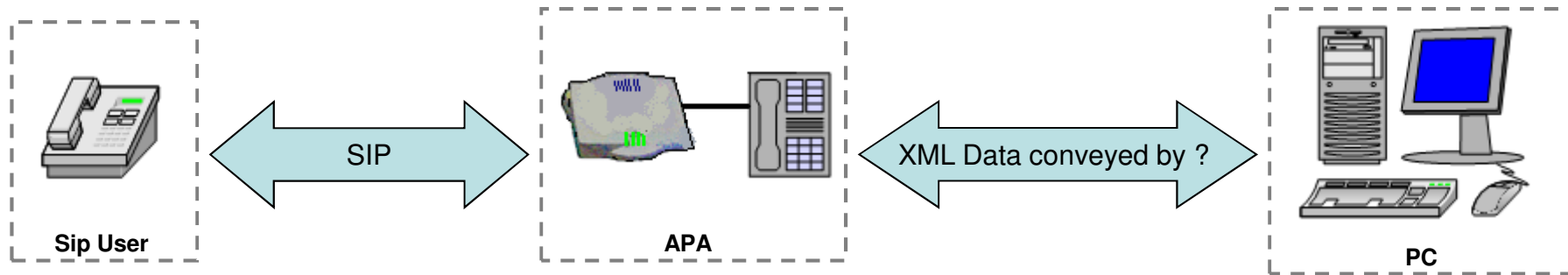

Web Protocol to transport XML Data ?

- HTTP : Having a HTTP listener (HTTP Server on the APA) ? Managing device presence ? Statefull ?
- SMTP : Same limitation as HTTP
- SIP : The Solution !!
 - Using the SIP Stack implemented on the APA (M5T SIP stack V 3.5)
 - Using the Payload of the SIP paquet to encapsulate XML message
 - Using INFO request through a session already established (session created by an INVITE between Storm devices) ? Or using Subscribe/Notify mechanism (Subscribe request to create a session and Notify request to convey the Storm XML messages ?
 - Using sip existing headers and probably some extra-headers

STORM : Sequence Diagram

Request line: NOTIFY sip:PC_SIP_URI SIP/2.0

Method: NOTIFY

Message Header

Max-Forwards: 70

Content-Length: ...

Via: SIP/2.0/UDP Local_IP_Addr;branch=z9hG4bKe89100756

Call-ID: a0ca01198b4afc1

From: APA_SIP_URI;tag=9f82847c9fbb5ee

To: PC_SIP_URI

CSeq: 7

Expires: ...

Event: From: Caller_Sip Uri

Content-Type: To: Called_Sip Uri

User-Agent: ...

Payload

<rpc>

<open>

<call>

<from>Caller_Sip Uri</from>

<to>Called_Sip Uri</to>

<call-id>Call-Id</call-id>

<cseq>CSeq</cseq>

<contact>Contact</contact>

</call-description>

</rpc>

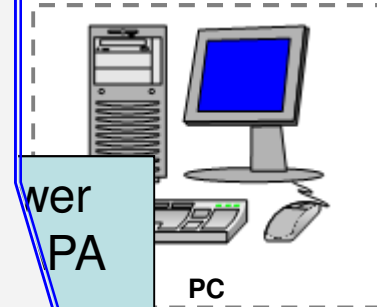

Server
PA

PC

New Call Received

A New Call was received:

From: Caller_Sip Uri

To: Called_Sip Uri

Action to take with this call:

Accept

Decline

Busy

Forward

STORM : Sequence Diagram

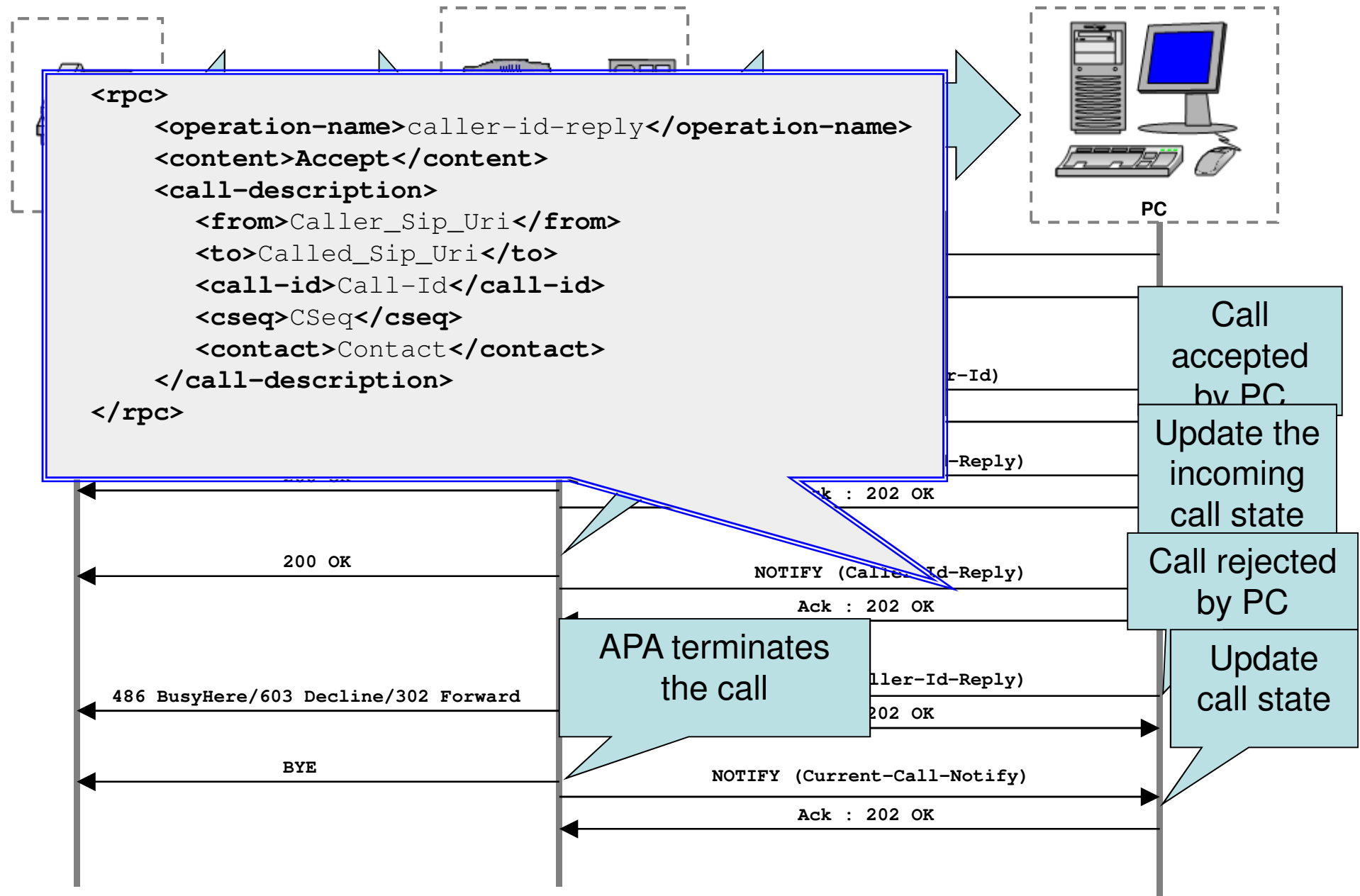

STORM : The Subscribe/Notify mechanism

- How to support the Subscribe/Notify Mechanism using the M5T Sip Stack V3.5 ?

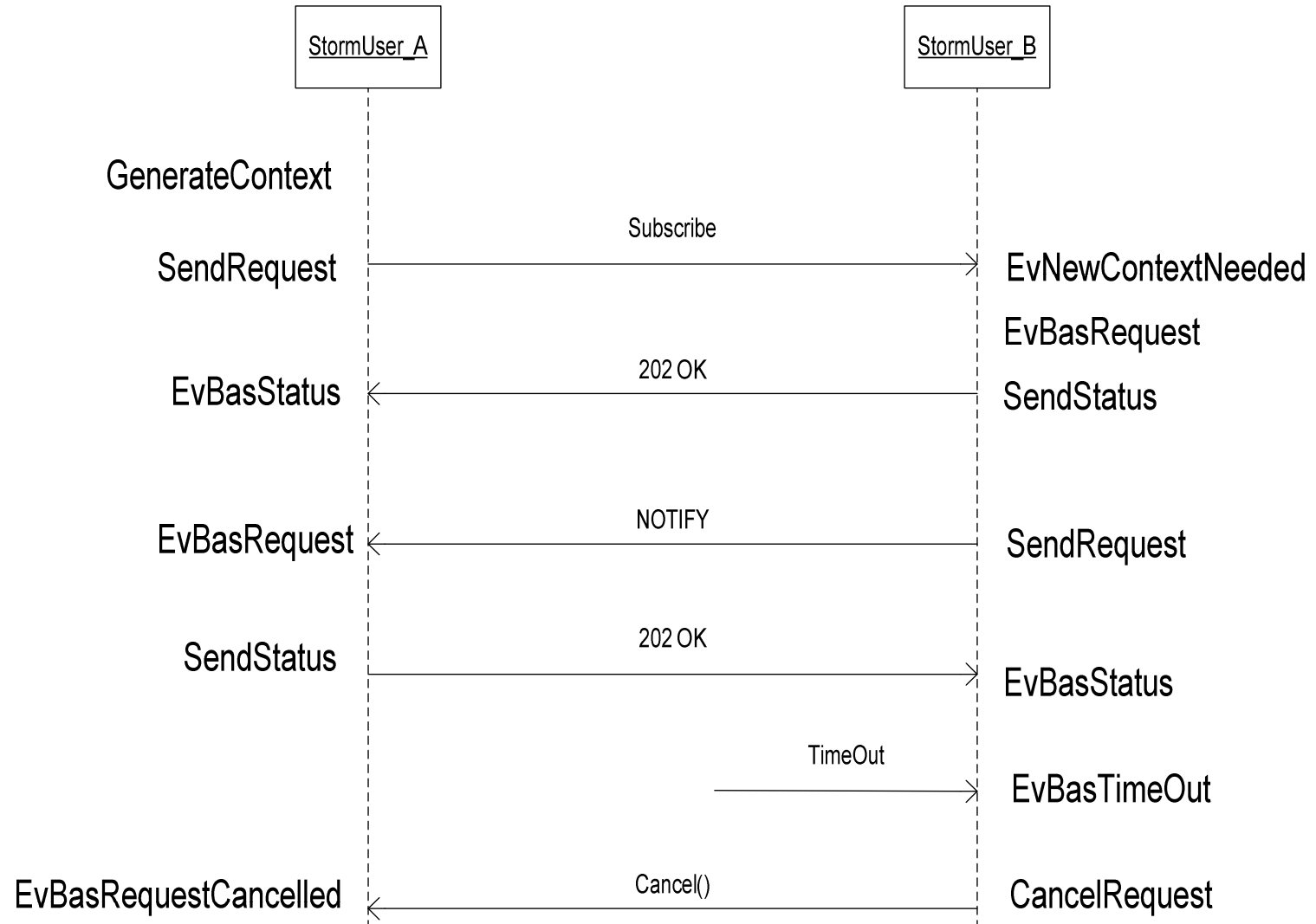

M5TFramework (MITOS)

Stack SIP M5T v 3.5

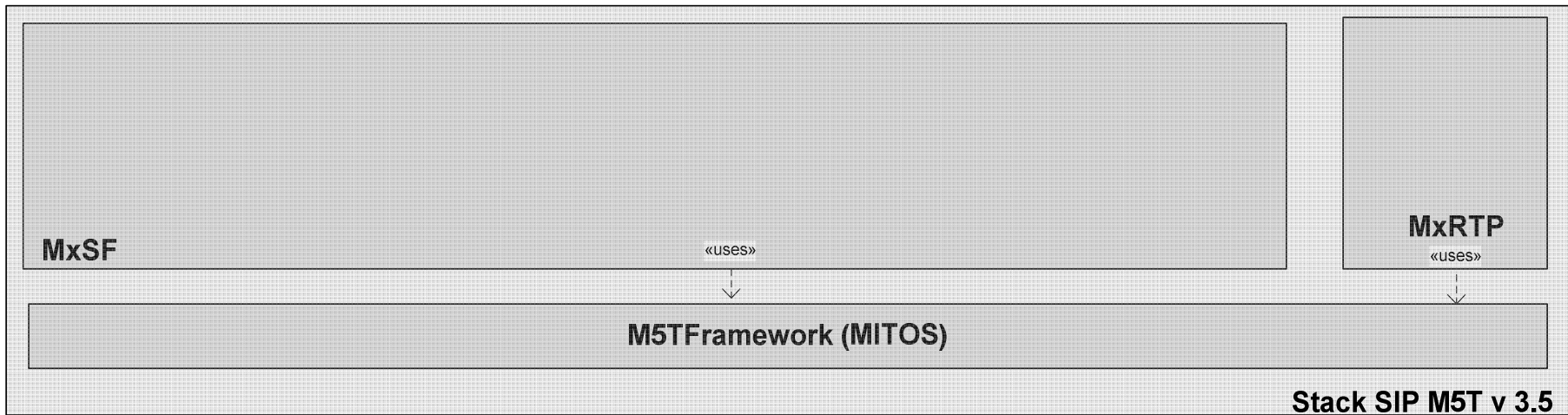

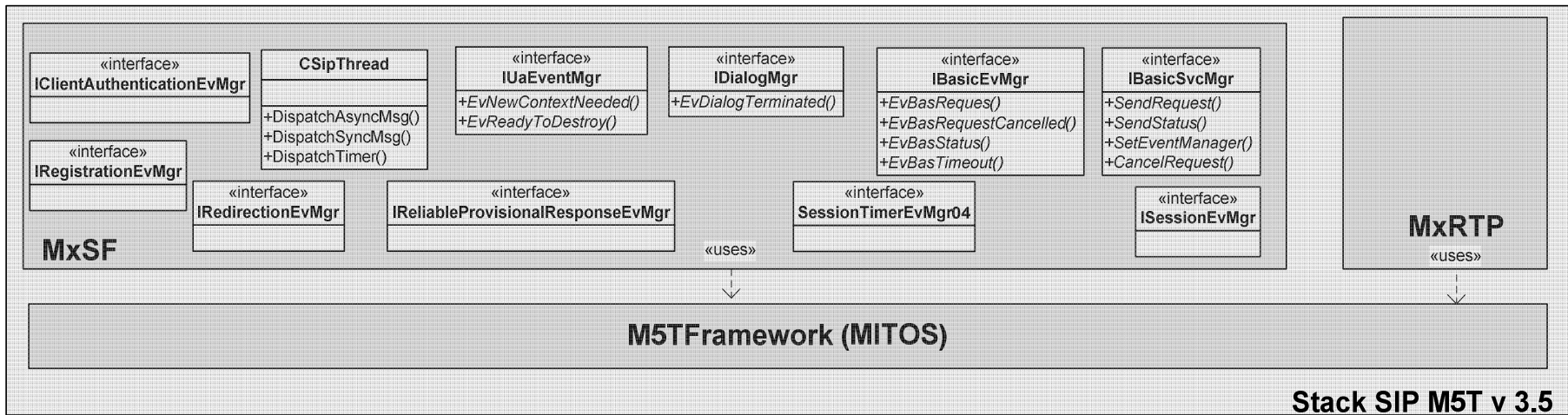

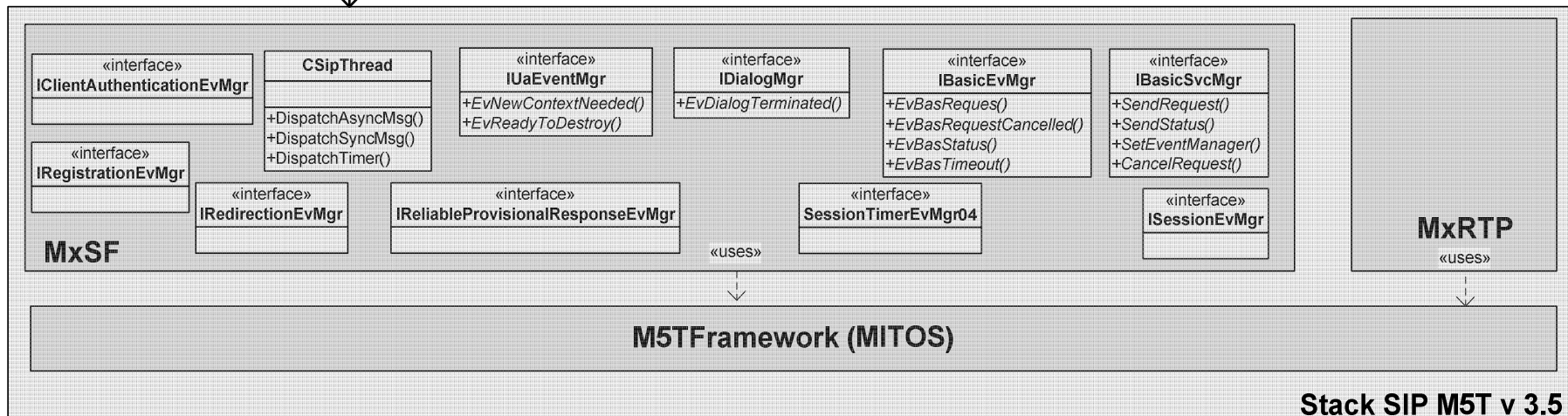
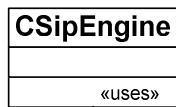

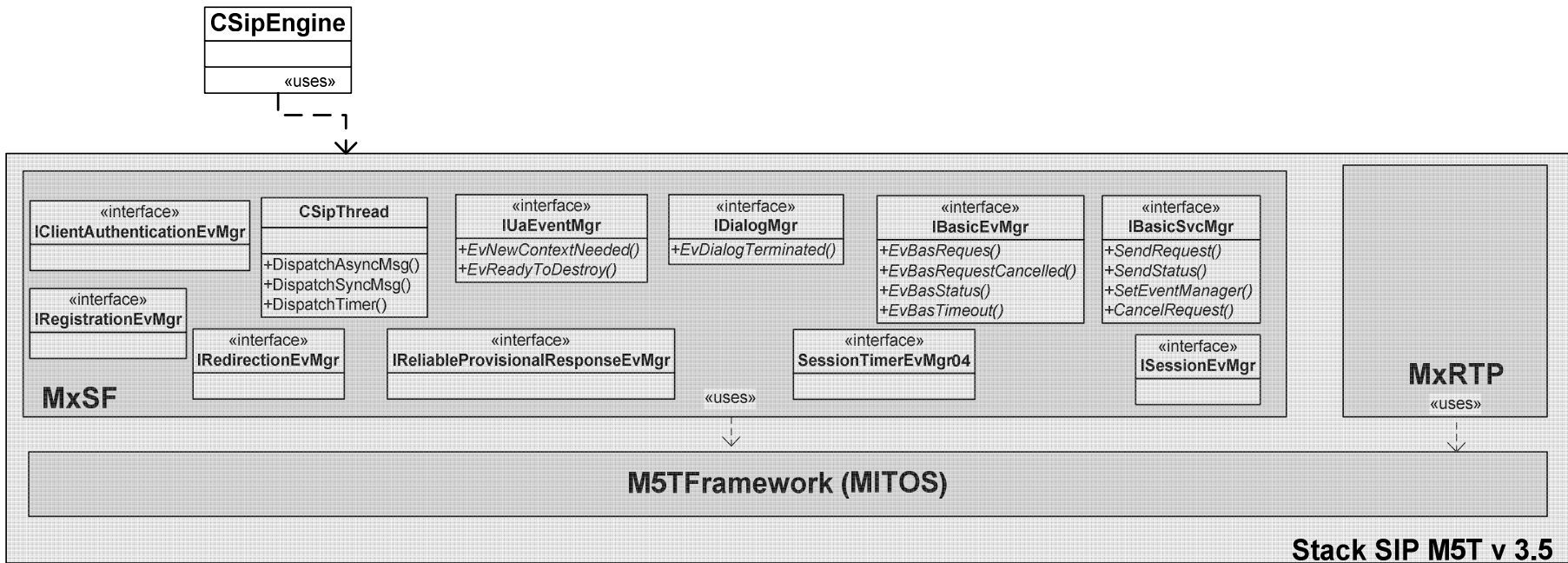
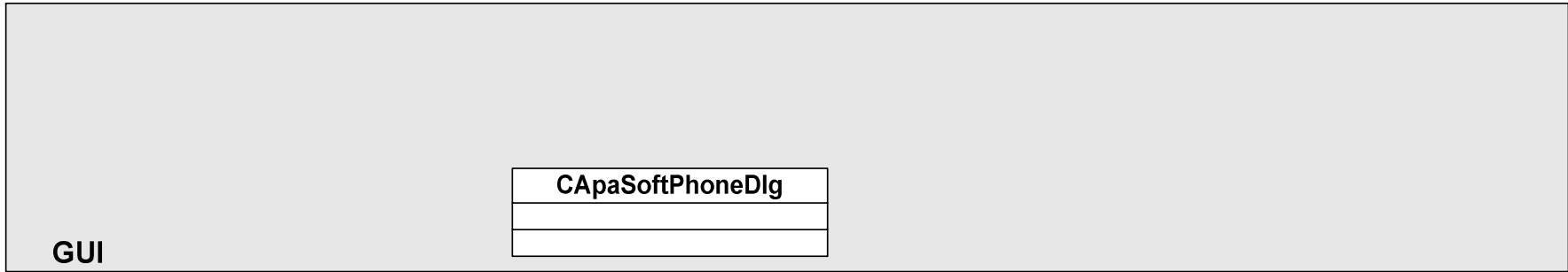

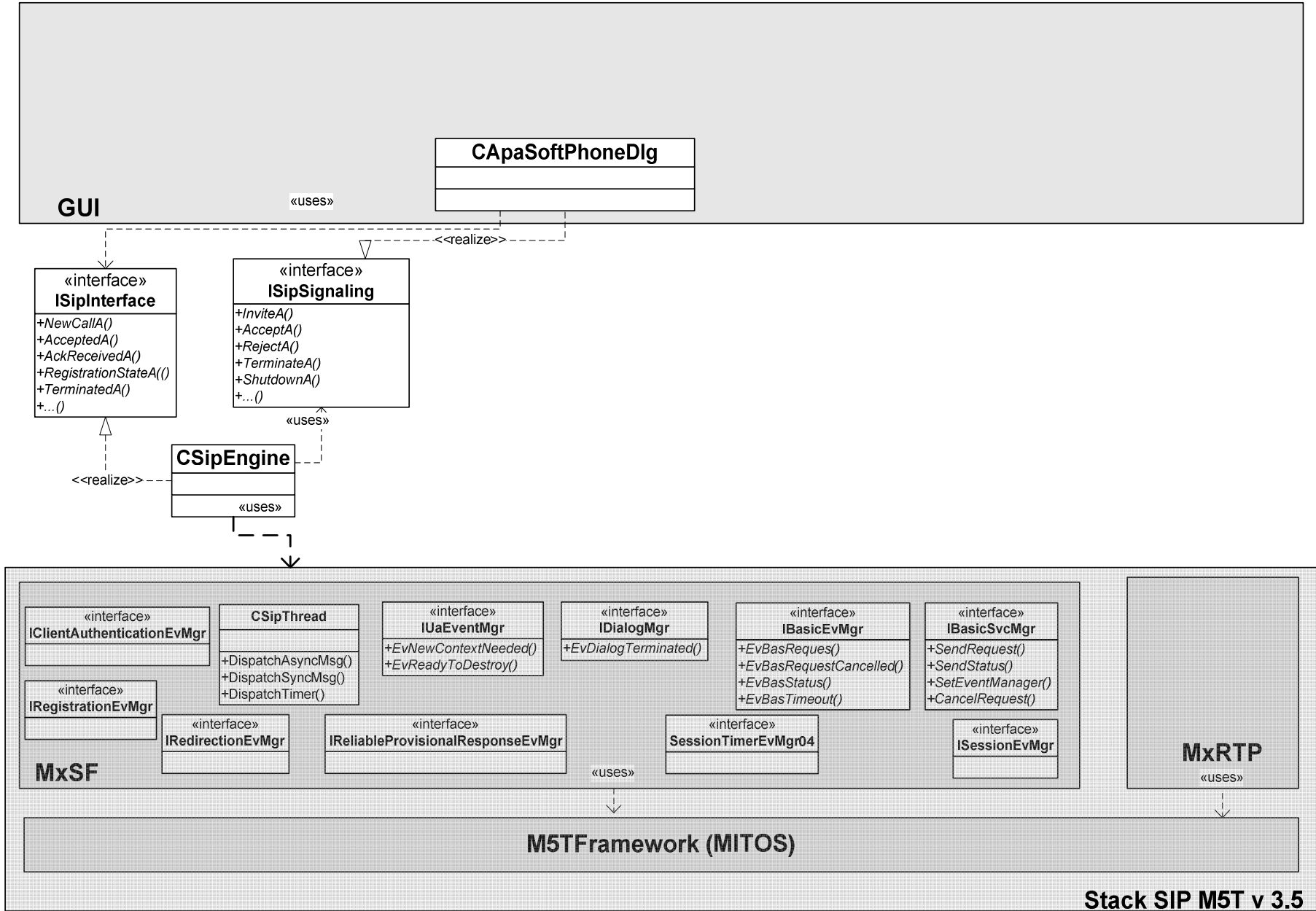

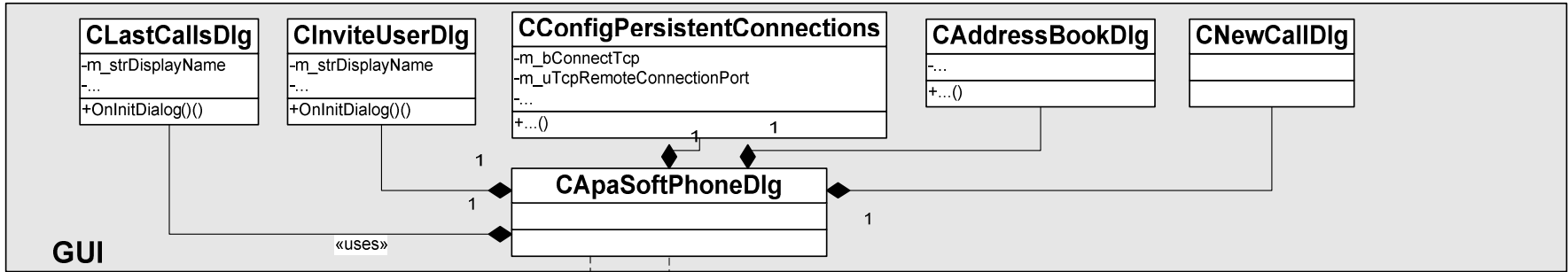

GUI

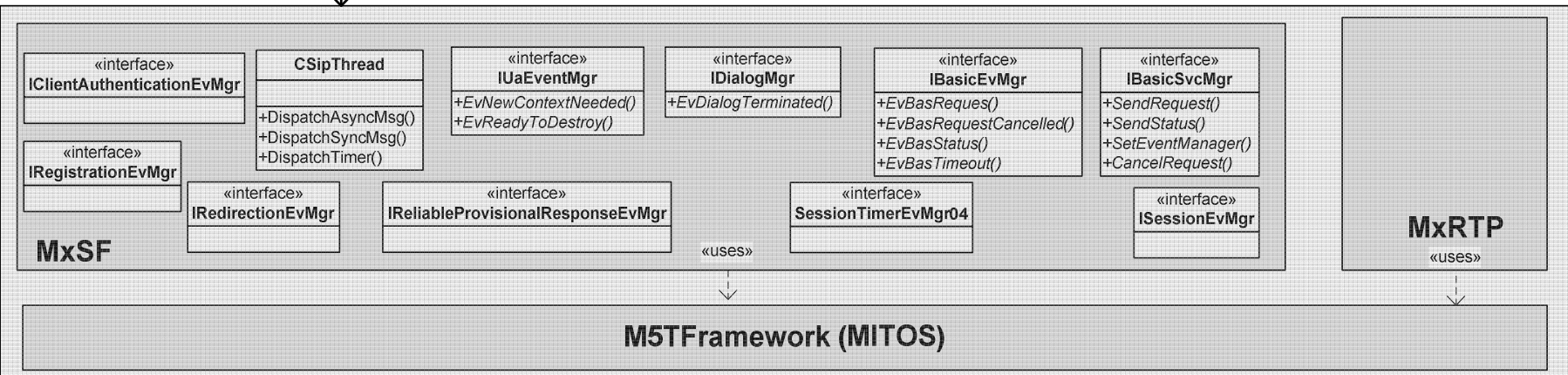
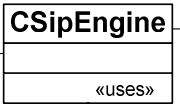
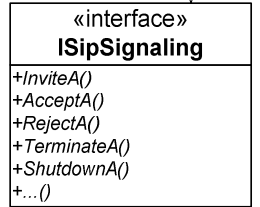
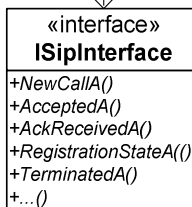

M5TFramework (MITOS)

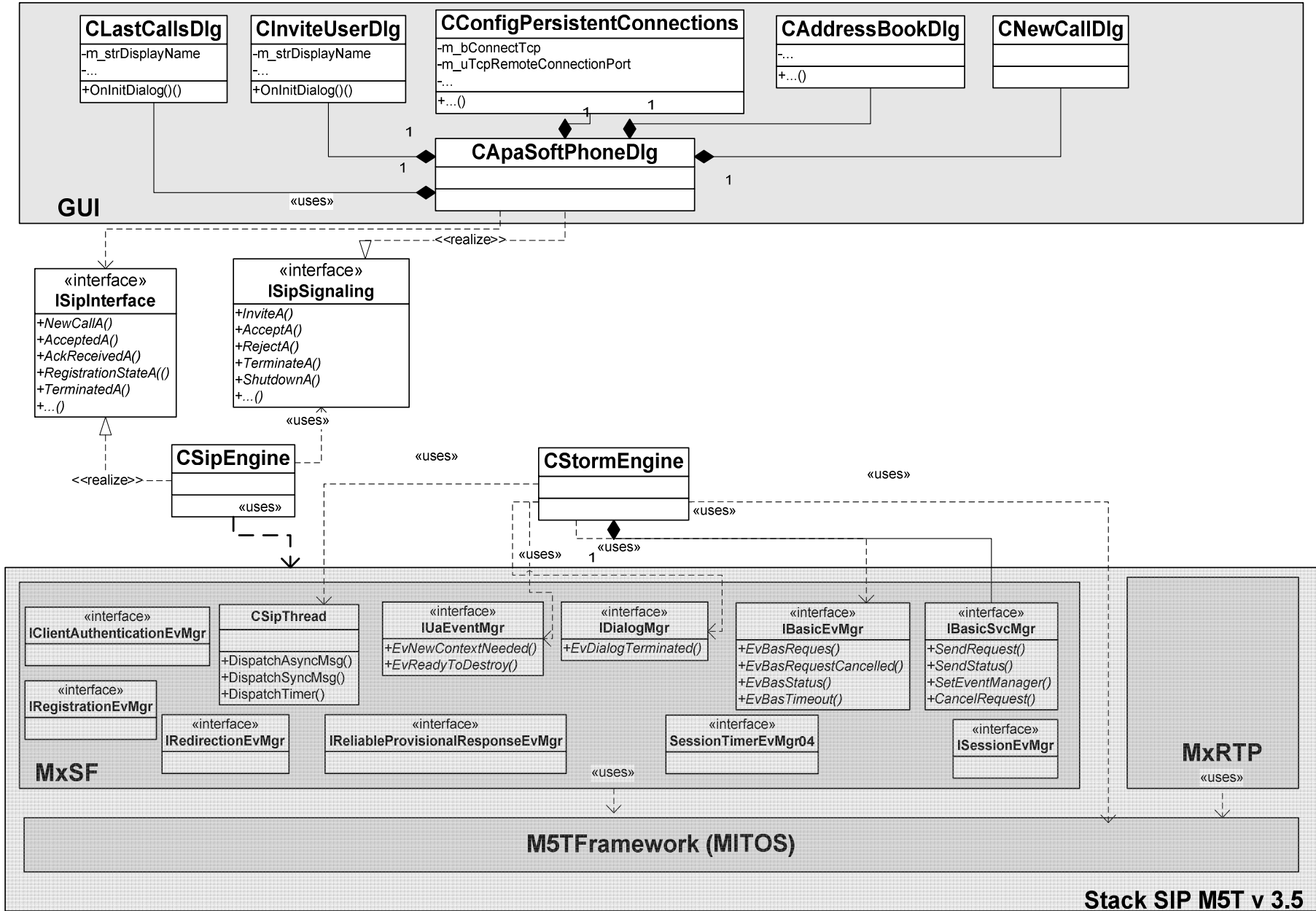

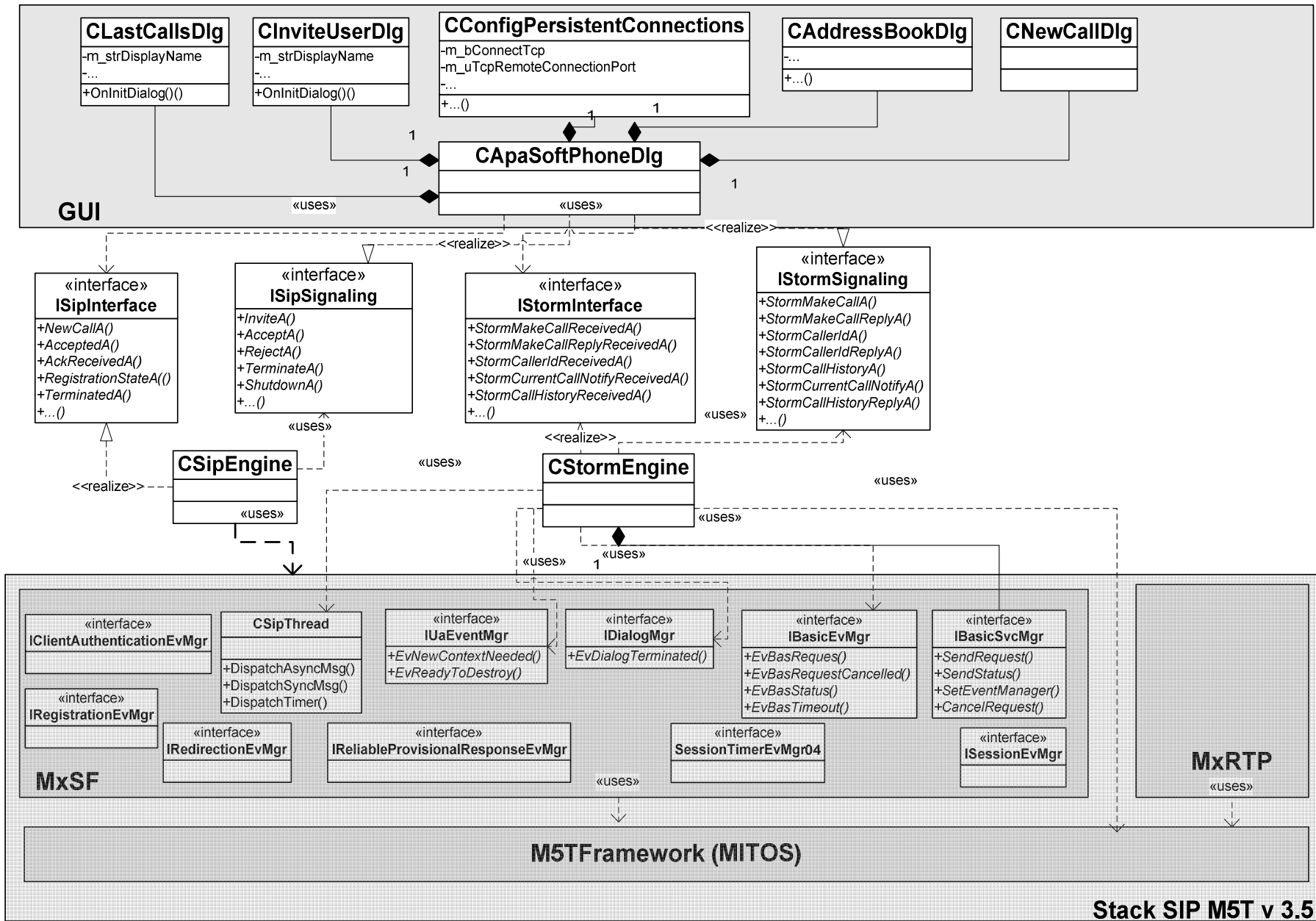

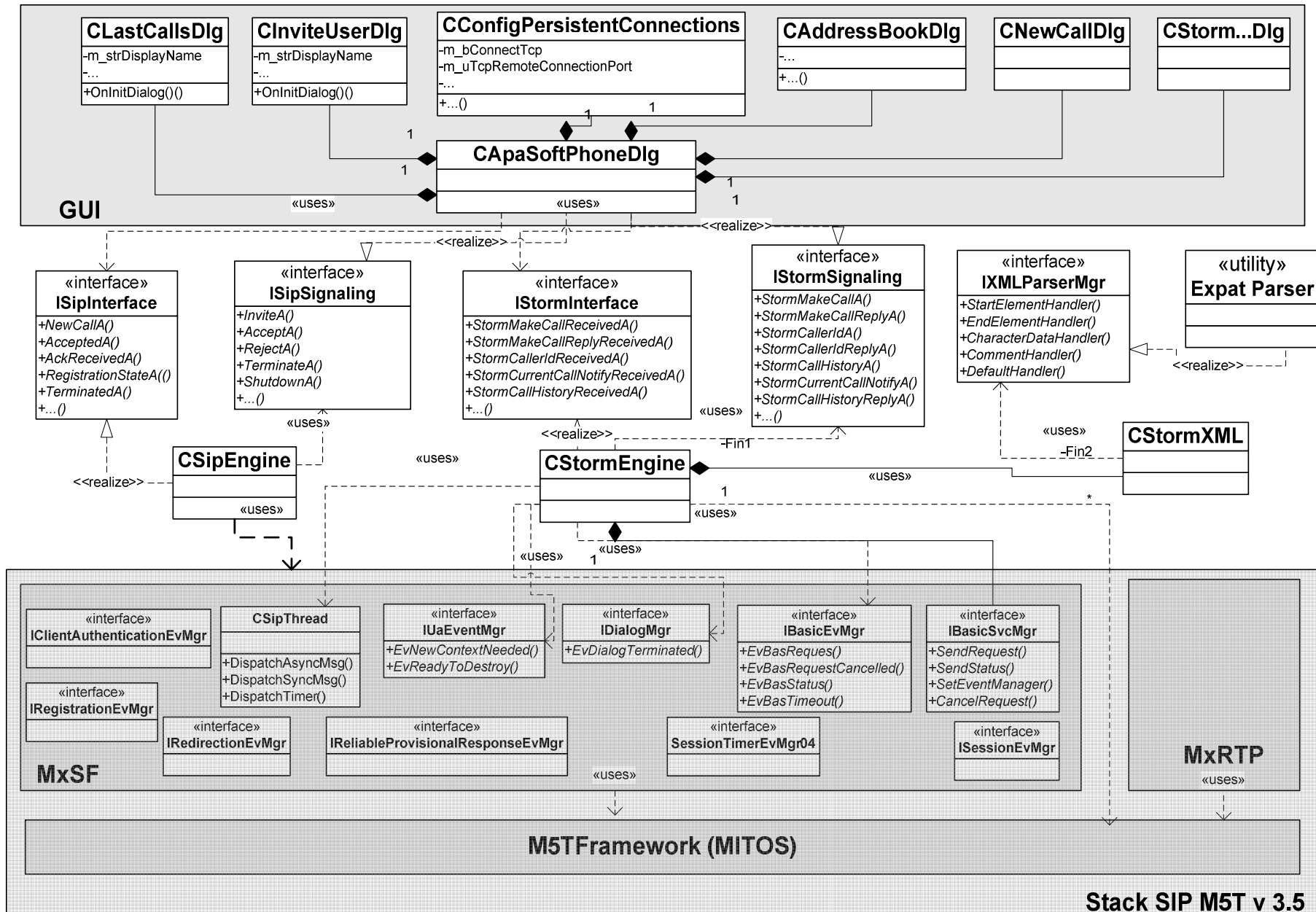

The Demo !